

# SPRAT

THE JOURNAL OF THE G QRP CLUB

DEVOTED TO LOW POWER COMMUNICATION

Special Edition

© G-QRP-CLUB

ISSUE 1

# The Pixie File



pixie /ˈpɪksɪ/ n. Also pixy.  
[Origin unkn.]

In folklore, a supernatural being with magical powers; a fairy, an elf.  
a tiny amateur radio transceiver.

From the pages of SPRAT - The Journal of the G-QRP Club.

Introduction by Tony – G4WIF.

Every so often a design captures the imagination of the QRP world. In 1982, George Burt - GM3OXX described the "Foxx" in the summer 1983 edition of SPRAT. His transceiver used only 5 transistors yet it featured both sidetone and R.I.T. This was probably the first QRP transceiver in history to use the same bipolar device as the transmit PA and the receiver mixer. Since then, designs of a similar nature appeared from both Europe and the USA. As the concept was continually improved, it became better known as "the Pixie".

In 2001 a new QRP club called "QRPP International" was formed. Their website says "QRPP-I is a club for amateur radio operators around the world to share their experience and knowledge as well as help others learn about the lowest power (less than 1 watt) and most fun aspect of amateur radio".

In the Fall of 2001, Brice D. Hornback - KA8MAV of QRPP-I decided to document the history and evolution of the Pixie.

This document from the GQRP club forms part of that history through articles that have appeared in SPRAT from 1982 to the present day.

To learn more about GQRP and QRPP-I visit our websites at:-  
[www.gqrp.com](http://www.gqrp.com) & [www.qrpp-i.com](http://www.qrpp-i.com)

"Pixie 2 - An Update" appears with the kind permission of Doug Hendricks □  
KI6DS. This article first appeared in QRPP June 1995



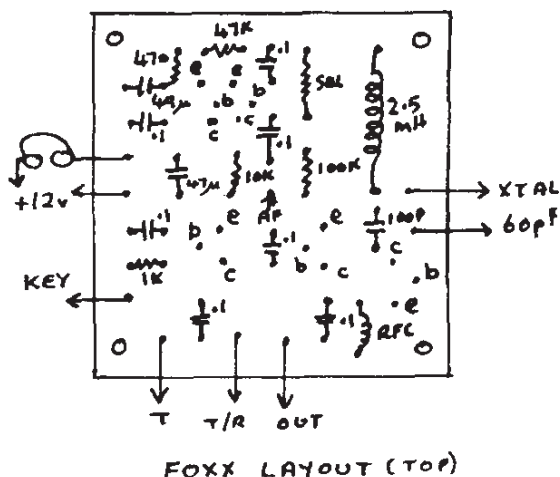
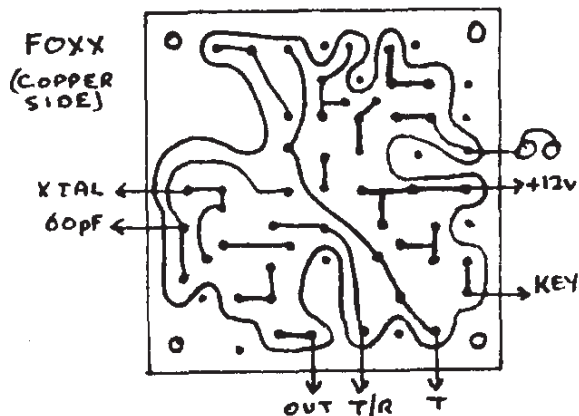

## G QRP Club Printed Circuit Boards

The club is now able to offer a series of etched and drilled printed circuit boards for club projects. They are:

THE S.C.D. TRANSMITTER BOARD £1.00

A simple beginners transmitter by G3RJV from 'Short Wave Magazine' supplied circuit and layout details.

G3ROO BROADBAND LINEAR AMPLIFIER £1.50 (undrilled)

A Linear RF Amp board ideal for SSB QRP PAs from SPRAT and Circuit Handbook usable 160-10M. Supplied with circuit and layout details.

THE STX £0.75

Simple transmitter featured in this issue

THE FOXX £0.85

Miniature transceiver featured in this issue

WARC CONVERTER £2.15

Receive converter by DL1ZB featured in this issue.

Cheques to "G QRP CLUB"

Postage charge of 20p on all boards.

From:

Mick Hodges, G4OPE, 51 Carnford Road, Sheldon, Birmingham. B26 3AG.

## Members Ad's

G3RJV is looking for a Manual (to borrow and copy) for a Trio 2200GX

FOR SALE: Argonaut 509 Stickers for QSL Cards, \$1.00 per page of 36. WB80WM, Skip Westrich, 1309-24th St. Canton, Ohio 44709.USA.

FOR SALE: ARGONAUT 509 (Excellent Condx) plus mike and cw filter 203 Unit. £225 ono - or exchange for Trio TS130V with cash adjustment. Vince Lewis, 19 Cowley Cres. Padiham, Lancs. Phone: 0282 72131(day) 0282 72916(evenings).

SWAP: Solid State Design for the Radio Amateur book for QRP HF Transceiver G4SQA, 24 Oakleigh Dr. Peterborough. PE2 OBD. Peterborough 232211.

FOR SALE: SEM 2 metre Converter (2-4MHz output) unused £10 p.p. ono. DFM partly assembled, complete with all parts, SWM articles and prefabricated case. offers invited. G8BAF QTHR Phone 0376 514912 (Essex).

FOR SALE: TENTEC PM3A £50 or o.n.o. G8CK QTHR. Stourbridge.

**THE MICRO-80      MINI-TRANSCEIVER**  
**Oleg Borodin RV3GM      P.O. Box 229, Lipetsk 43, U.S.S.R.**

Oleg offers members the circuit of his miniature MICRO-80 Transceiver which is produced in kit form by his small company Radio-S. The circuit is a simple QSK transceiver for 80 metres which could be adapted for other bands by changing crystals and L and C in Q4. The devices quoted are Russian types but any generic transistors should perform in the circuit. Q1-3 would probably work with BC108 and perhaps a 2N3866 for Q4. The rf choke is around 100uH and could be home-wound with 180 turns of 0.1mm wire on a ¼ watt resistor of high value : say over 400K. L is wound with 18 turns [5+13] of 0.33mm wire on an 8mm former with ferrite core. Oleg's suggested layout is used on a PCB 50 x 35mm. He says, 'Is this the world's smallest transceiver ?'

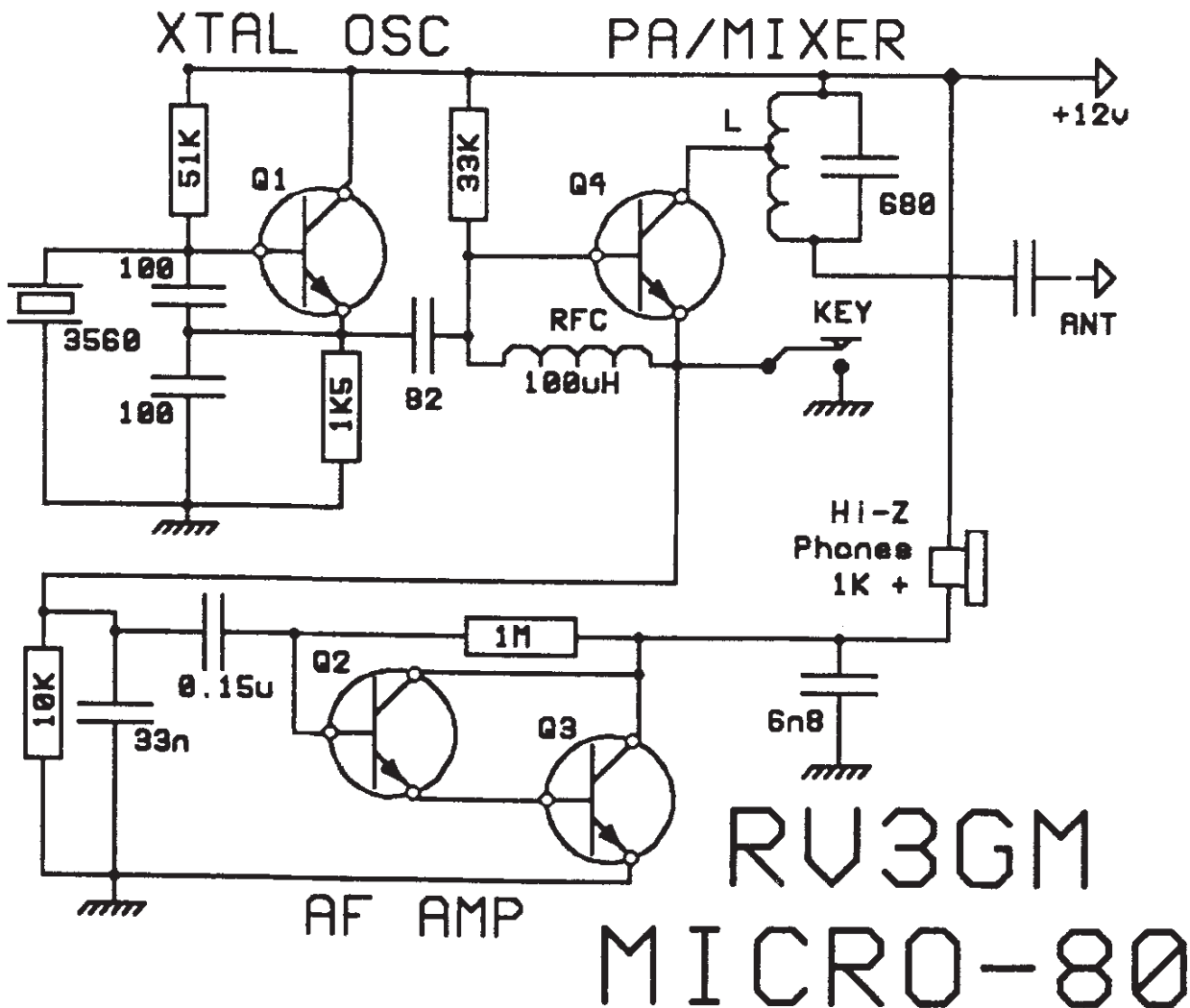

**THE HB9ADQ MUTLIBAND DELTA LOOP : A Plea from W5QJM.**

Main Reference. Simple Low Cost Wire Antennas. Orr. 1990 edn. p.60

Several variations of this antenna [all claiming to original] have appeared in abbreviated form in US magazines, none has been complete. In fact the more articles that have run, the less and less is said about the antenna and how it works! No one has cited the source of this design or otherwise offered an explanation of more than is seen in the Orr ref. While there is general agreement about the dimensions of the loop proper, there are variations in feeder length and methods of feeding. It occurs to me this would be a good design for QRPer's with limited space. I would like to try it too, but have neither the inclination to re-invent the wheel by duplicating HB9ADQ's work to arrive at the same point as he did.

CAN ANYONE HELP?

**Fred Bonavita, W5QJM, Box 2764, San Antonio, Texas 78299-2764, USA**

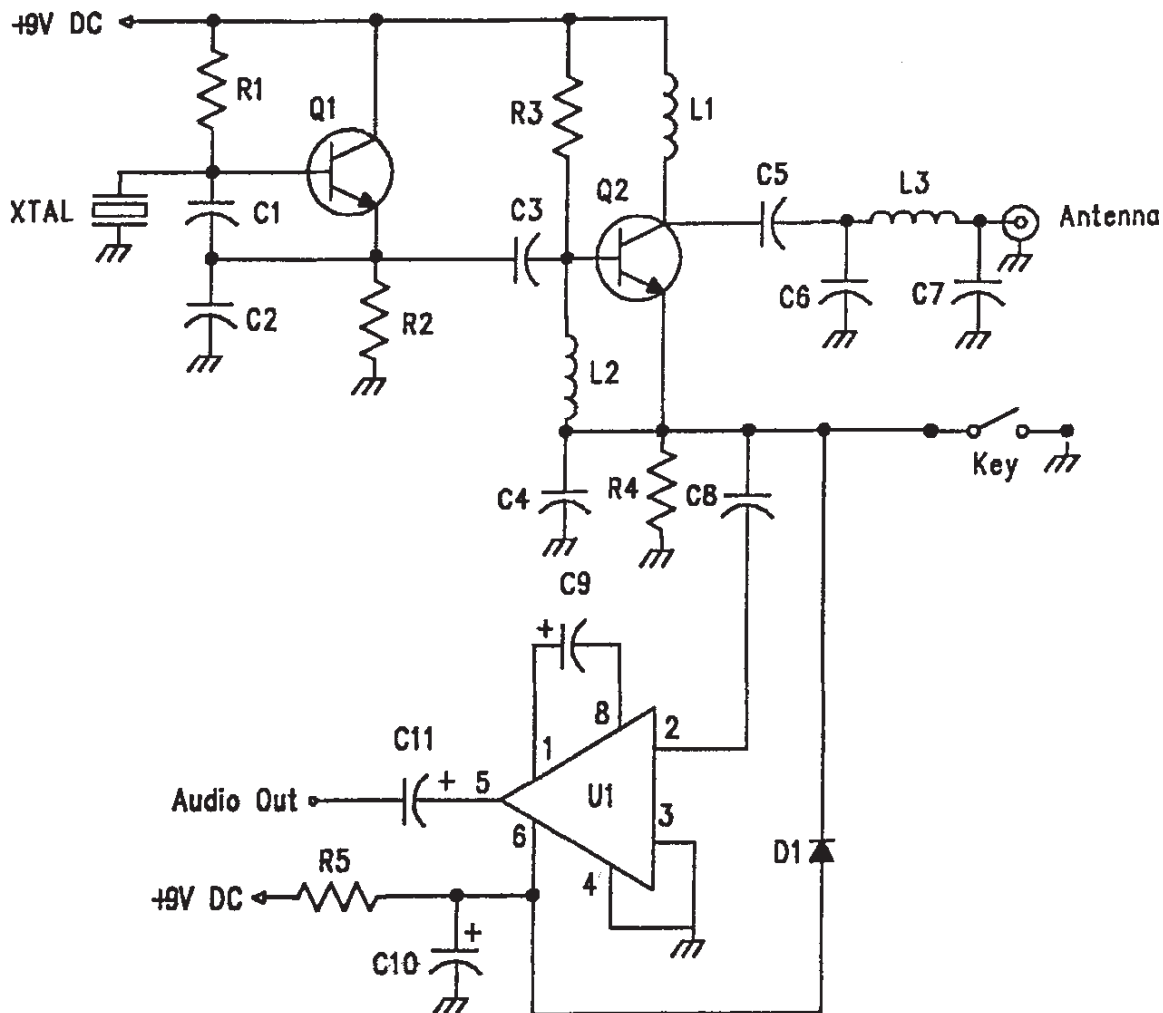

Parts List					
C1,2	100pF	C9,10,11	10uF/25V Elec	R1	47K
C3	82pF	D1	1N914	R2	1.5K
C4	.05uF	L1	15 - 22 uH Choke	R3	33K
C5	.01uF	L2	100 uH Choke	R4	10K
C6,7	820pF	L3	40M - 1uH	R5	1K
C8	0.1uF		80M - 2.2uH	U1	LM386

Fig. 1 Pixie 2 Schematic

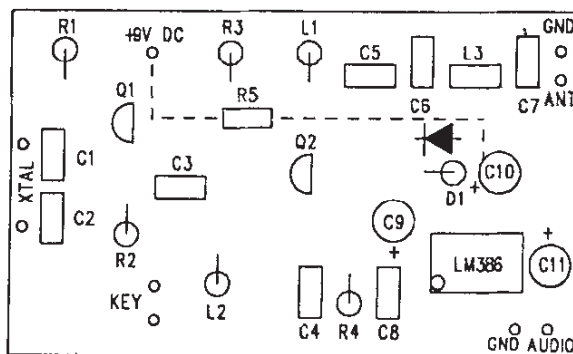
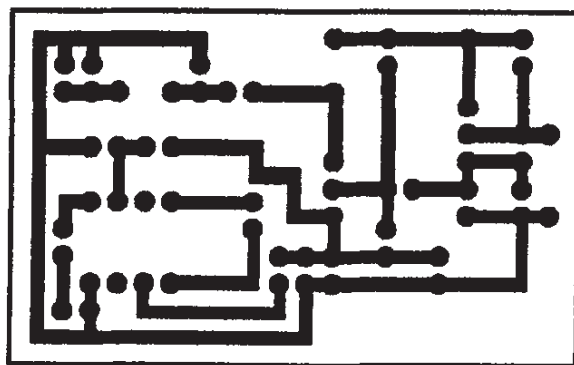

## The PIXIE 2 : An Update by WA6BOY

Reproduced from QRPP June 1995 (Northern California QRP Club)

# The PIXIE Goes On..... more on a popular idea

Derrick Webber G3LHJ, 43 Lime Tree Walk. MILBER, Newton Abbott. TQ12 4LF

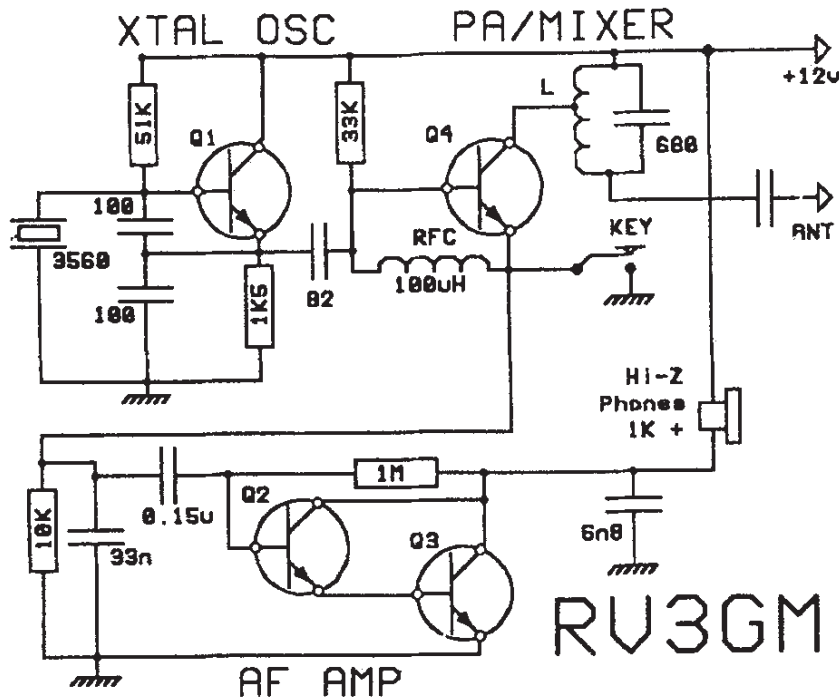

*Historical Note: SPRAT 72 (Autumn 1992) contained a very simple transceiver circuit, The MICRO-80 by Oleg Borodin, RV3GM. The idea has undergone several incarnations. One of the latest being the VU-QRP Club Mini-Transmitter in this issue. The PIXIE 2 a Californian version of the circuit.*

RV3GM

I built my Pixie after hearing George G3ICO and the two Pixies met and were compared at the Yeovil QRP Convention. I have been having good fun with it. When I first put it on the air there was a problem in that everyone was coming back to me nearly zero beat. This made copy difficult so I made some modifications.

I lifted the ground end of the crystal and with a STDP switch on the front panel (marked [T]ransmit and [R]eceive) selecting two capacitors, 1000pF and 40pF. This gave me my 600Hz offset and all was well. See the drawing. I use an internal PP3 battery but backed this up with an outboard power socket.

## The G3LHJ Version of W6BOY's PIXIE 2 from QRPp of June 1995

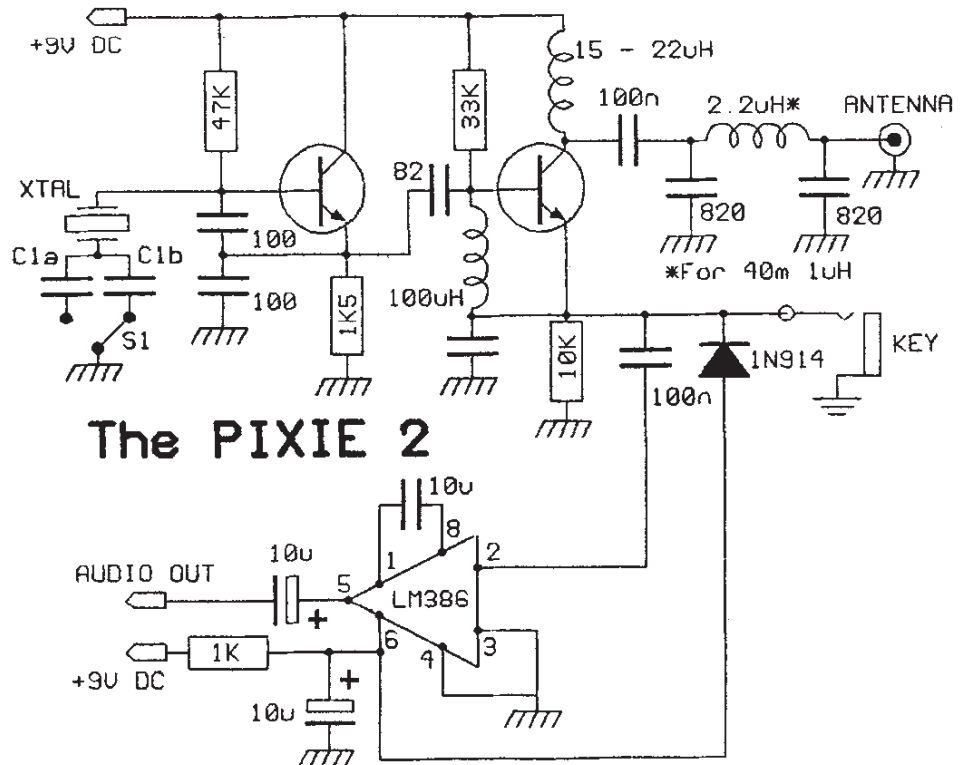

I could not find a mustard tin for mine so I made a home for the Pixie. It is a simple base plate with bent up front and back panels. The size is 3" x 1 1/4" x 3 1/2" deep. Total QSOs to date is 18 and the best DX is G3JNB in Norwich.







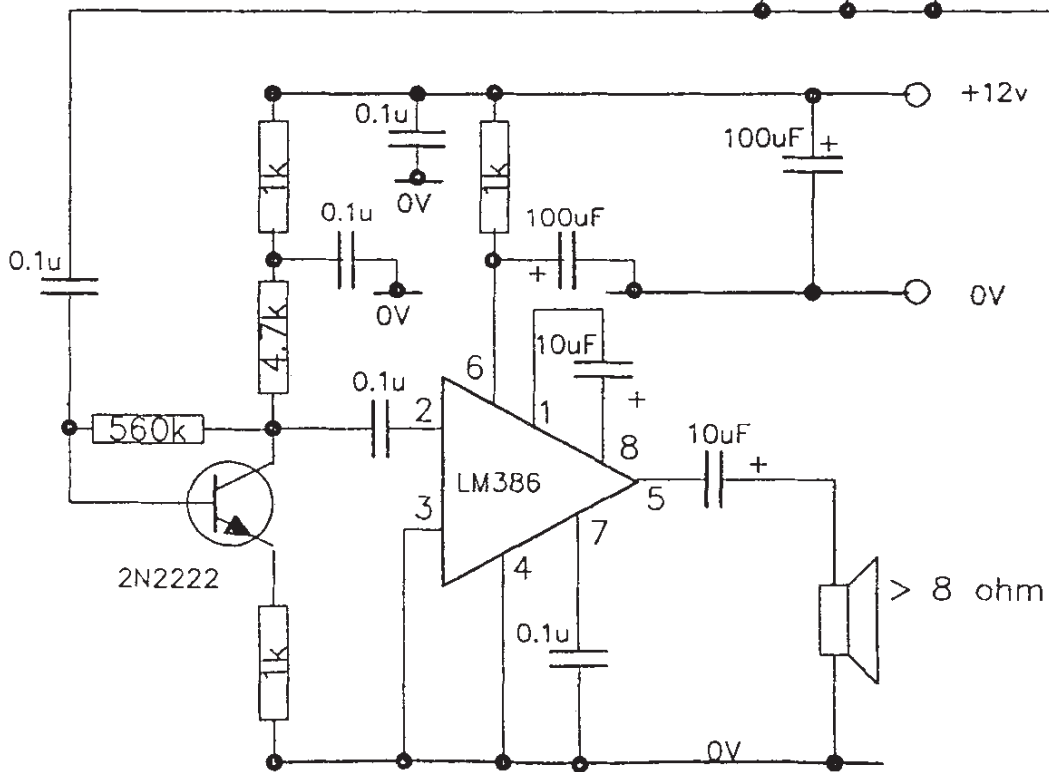
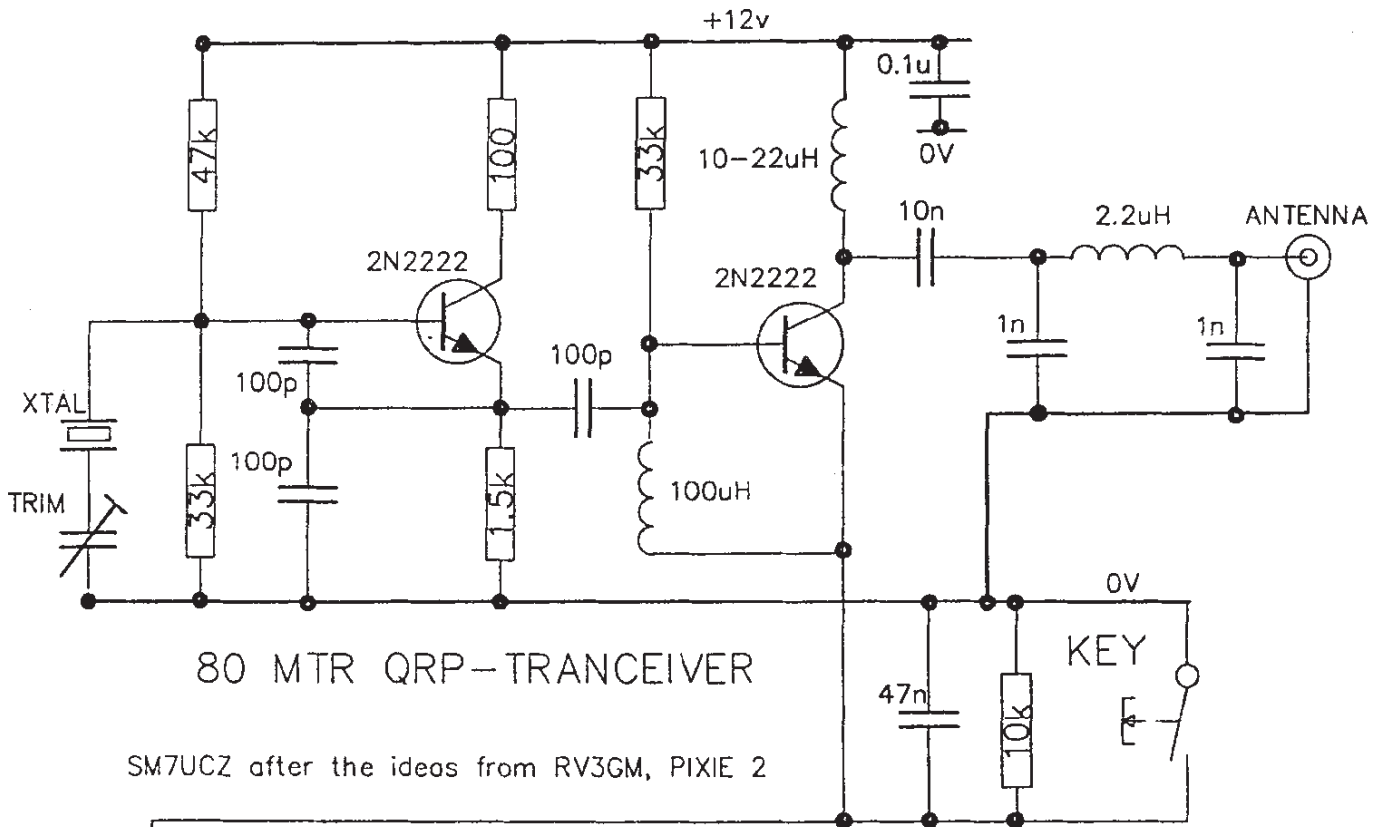

## The ÄLVA

## THE FOXX 2 - An Old Favourite Revisited

### G3RJV after George Burt GM3OXX

In recent times a lot has been written about the simple PIXIE transceiver based upon the Micro-80 of RV3GM. Both use the transmit PA transistor as the mixer on receive. But this was not a new idea. In the summer 1983 issue of SPRAT, that master of the simple radio circuit, George Burt, GM3OXX, described his FOXX transceiver. An elegant little circuit which used the same transistor for the transmit power amplifier and the receive mixer. It is capable of transceiver operation on several bands and generates around one watt of RF power out. To keep the simple transceiver ideas flowing, I thought it a good idea to revise the FOXX circuit with a few changes.

TR1 is a VXO (Variable Crystal Oscillator) stage. The feedback loop formed by the crystal and the trimmer capacitor (C1) tunes the circuit to the desired frequency. C1 provides a small amount of frequency shift. The output is coupled to a Power Amplifier stage. This stage is unusual in that a PNP transistor is used with the emitter connected to the positive supply and the output taken from the collector load which goes to ground. The output of the transmitter may be adjusted by a resistor (Rx - a few hundred ohms) to around one watt of output power. TR2 should be fitted with a clip-on heatsink. TR3, another PNP transistor allows the transmitter to be keyed with respect to ground. TR3 and TR2 are both 2N2905A PNP switching transistors.

The low pass filter is a seven element circuit based on the circuit and constants described by W3NQN. The transmit - receive function is performed by a double-pole, double throw switch, SW1 A and B. The receive position has two functions. It bypasses the keying transistor, TR3, to ensure that the oscillator TR1 remains on during the receive position to provide the local oscillator. It also switches the supply line away from the power amplifier, TR3, and connects TR3 to the audio amplifier. In this position TR3 functions as a diode mixer, mixing the signals from the antenna which appear at the emitter and the signal from TR1.

The audio amplifier is an LM386 working in maximum gain mode. The supply for the LM386 is taken directly from the 12 volt supply line which means it is on during both transmit and receive functions. This has the advantage of providing a rudimentary sidetone to monitor the keying. Side "tone" is an over statement because all it does is produce clicks in time with the keying.

A pre-set potentiometer is added in series with the TR1 supply on receive. This is a very simple form of RIT (receiver incremental tuning). If the supply voltage to TR1 is reduce enough, it shifts the frequency of the oscillations. Assuming the value of Rx to be in the order of a few hundred ohms (just to reduce the drive from TR1 a little on transmit), a 1K preset at R6 can be set to shift the frequency by around 700 - 800 Hz giving a comfortable off-set for CW reception.

#### VALUES FOR LOW PASS FILTER FOR FOUR BANDS

Band MHz	C1,7 pF	C3,5 pF	L2,6 turns	L4 turns	Core	Wire swg
3.5	470	1200	25	27	T37-2	28
7.0	270	680	19	21	T37-6	26
10.1	270	560	19	20	T37-6	26
14.0	180	390	16	17	T37-6	24

Note : Wire gauge is not critical.

Use size to comfortably fill the core about three-quarters of full circumference.

#### KITS FOR THE FOXX 2 AT A SPECIAL CLUB PRICE

**Kanga Products are offering 100 FOXX 2 Kits  
to members only - at only £10 each plus £1.50 pp**

# FOXX2 TRANSCEIVER

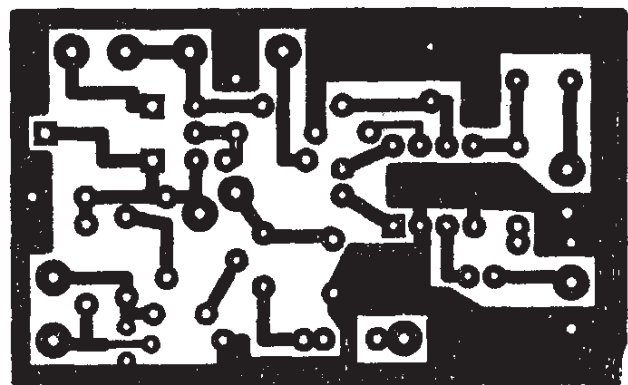
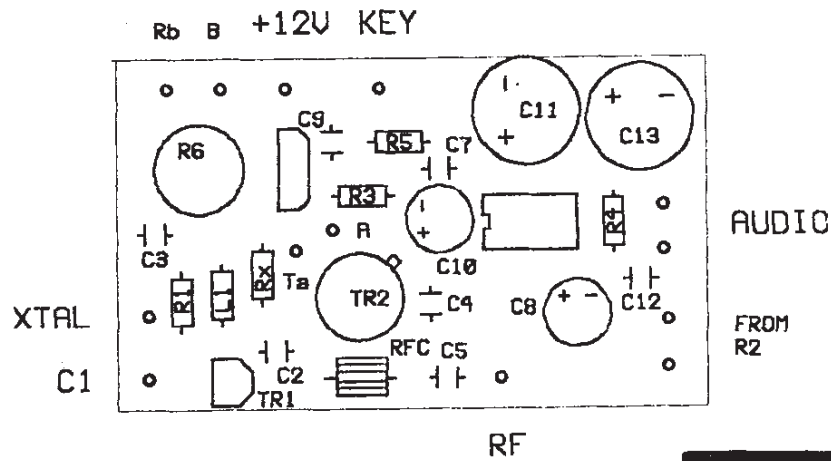
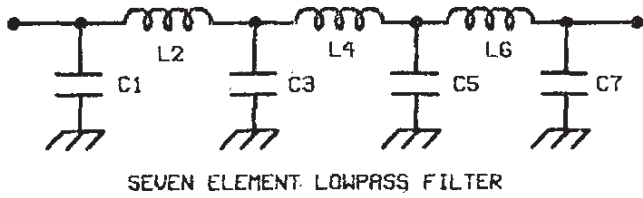
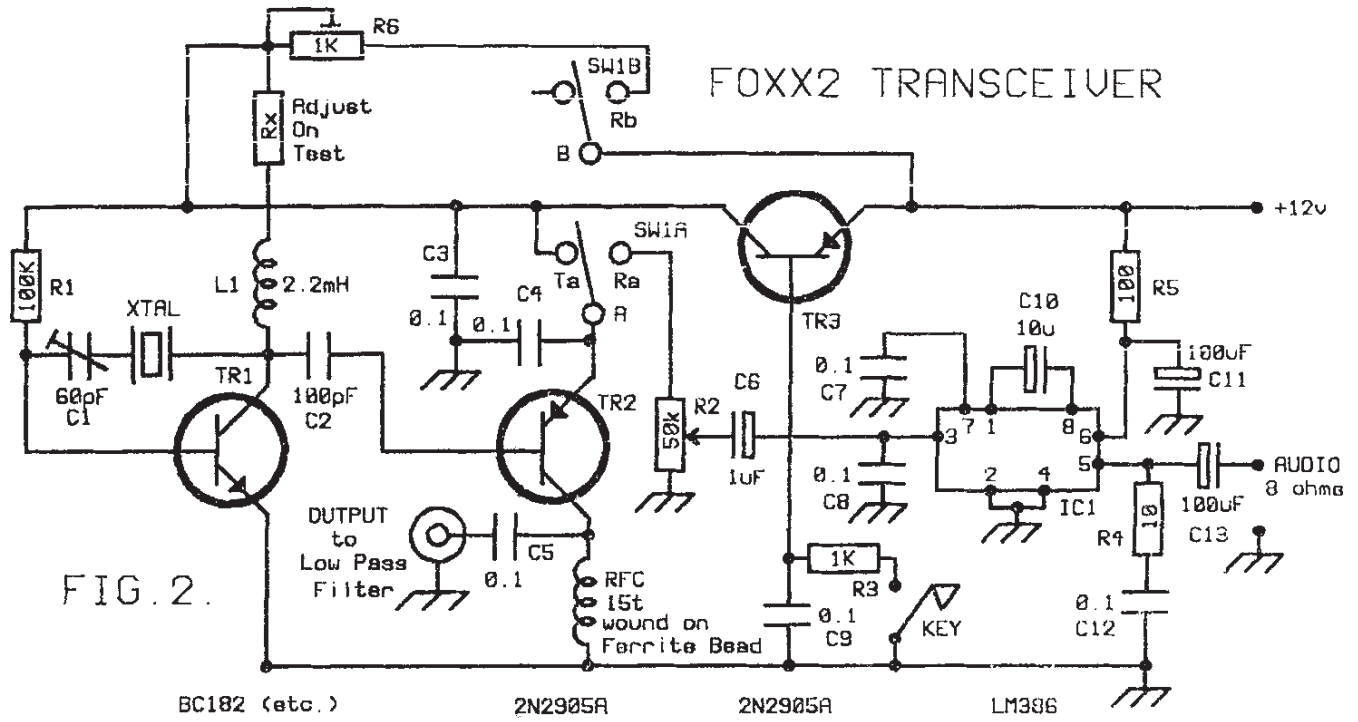

A different solution is as follows: See Fig. (3):

A tuned circuit was used instead of the single choke. The Transformer is made up from a FT 37-61 toroid core. The primary winding with the parallel caps is connected between pin 1 - ICC 2 as described above. Desolder C28 from pin 1 - IC2 and pull upwards, Secondary winding is soldered between ground and the free end of C28, Adjust the trimmer to the IF of 4.4336 MHz. The last mod is a bit tricky, because all part must be soldered on the component slide of the PCB and as near to IC2 as possible. Weak signal reception is now much better.

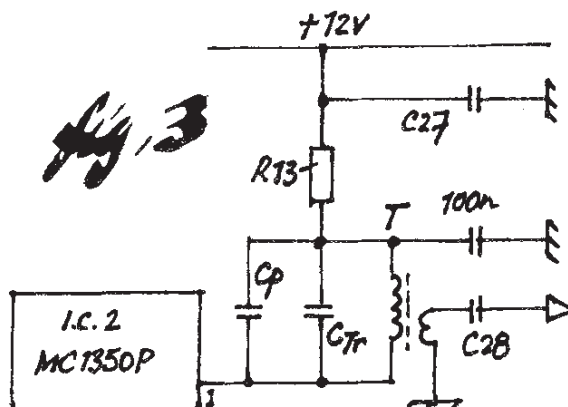

T = FT37-61. Pri. 15t 34swg, sec. 7t 34swg. Cp : 100pF NPO, Ctr : 35pF adjust for max. RX sigs.

### More Mileage from the Pixie

George Davis, G3ICO, Broadview, East Lanes, Mudford, Yeovil, BA21 5SP

Just in case your thought the maximum mileage had been extracted from the Pixie, I have now been using it with VXO. Using a ceramic resonator, 3580kHz, and a 60pF variable capacitor, I can cover from about 3550 to 3585. To date I have had 31 QSOs with the Pixie 2, including one 2 way Pixie QSO with G3LHJ, one "F", One "GM", one "GW" and one "EI". I have even had some mini Pixie photos produced for sticking on QSL cards for Pixie QSOs!

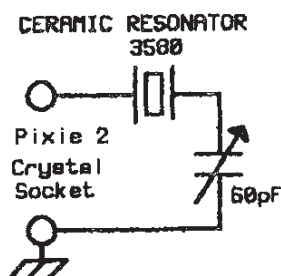

## Radio Projects for the Amateur

by Drew Diamond, VK3XU (Reprinted, with permission, by the G QRP Club)

Workable plans for the construction of receivers, QRP transmitters, transceivers, test equipment, and some handy construction hints for the practical radio amateur.

Available for £6.00 (plus UK postage £1, EEC postage £1.75) from :

Ian Wye GØOKY, New House, Hook Road, Amcotts, Nr. Scunthorpe, DN17 4AZ

Please make out all cheques to "G QRP Club" (an address sticker helps)

### MEMBERS REQUESTS:

**HELP WANTED:** Rod Wilson, G4BFP, is wheelchair bound and almost blind. His friend Don, G4YSU is trying to find suitable HF [phone] equipment to enable Rod to operate from a ground floor flat. If anyone can offer help or advice, please contact : Don Hodginsob, G4YSU, Ferndale, Liverpool Road, Much Hoole, Preston, PR4 4RJ.

**STOLEN ITEMS :** Stolen with two duplicate keys from a private apartment in Germany, these items of a radio collector: Transistor Radios [1960-70] 3 Schaub-Lorenz T 20, T 40, T 50 / 2 Russian VF 601, 1 Saba. Greman and English vintage wireless literature - each item engraved "WB", "W. Brox", "Oberursel" Each radio requires restoration. Reward for return of property and proof about producers of duplicate keys. Mr. W. Brox, PO Box 110302, 60038 Frankfurt/M, West Germany.

## The Maidenhead PIXIE

Peter Howard G4UMB, 188 Dashwood Ave. High Wycombe, HP12 3DD

This is a version of the PIXIE transceiver built in sections on versoboard by members of the Maidenhead Radio Club as a club project.

It has the following advantages:

- Runs more power – up to 800mW
- Has no oscillator running between keying, which was annoying for local working.
- Good offset of about an octave. Set up with another receiver by adjusting to the trimmer capacitor to the first two notes of “Somewhere Over a Rainbow” !
- It includes a sidetone

The six-pole switch is a push latching switch sold by Maplins. Only a single switch is required not a full bank.



## Weatherproofing PL259 Connections

Alan Gray G4UEV, 59 Little Mead, Hatfield, Herts, AL10 0UQ

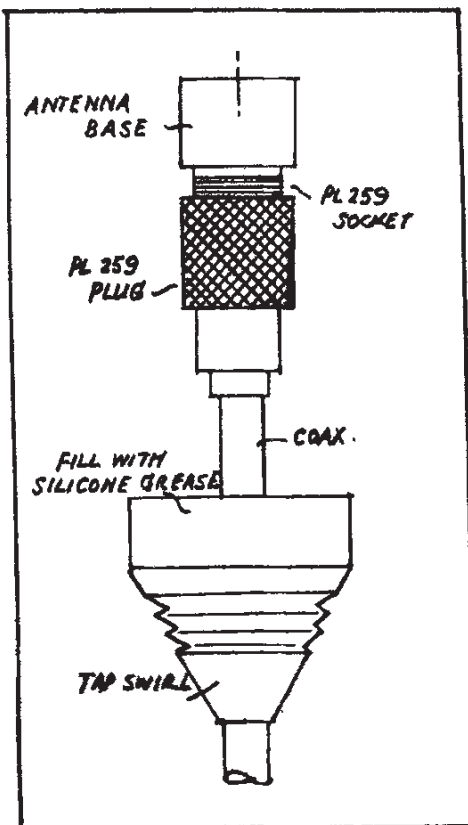

When I made my 25 ft vertical antenna, I needed to protect the PL259 plus and socket for the weather.

Being a hoarder of all sorts that will come in useful later, I found a discarded small rubber tap swirl in the junk box. I tried it over the PL259 and found it was a tight fit.

It has been out in the weather for some four years now and the PL259 plug is as good as new with no water ingrees .



## German QRP Club Members MEETING IN MAY 1998

Please contact Rudi before the end of January  
Rudi Dell, DK4UH, Weinbietstr. 10, 67459, BOEHL-IGGELHEIM

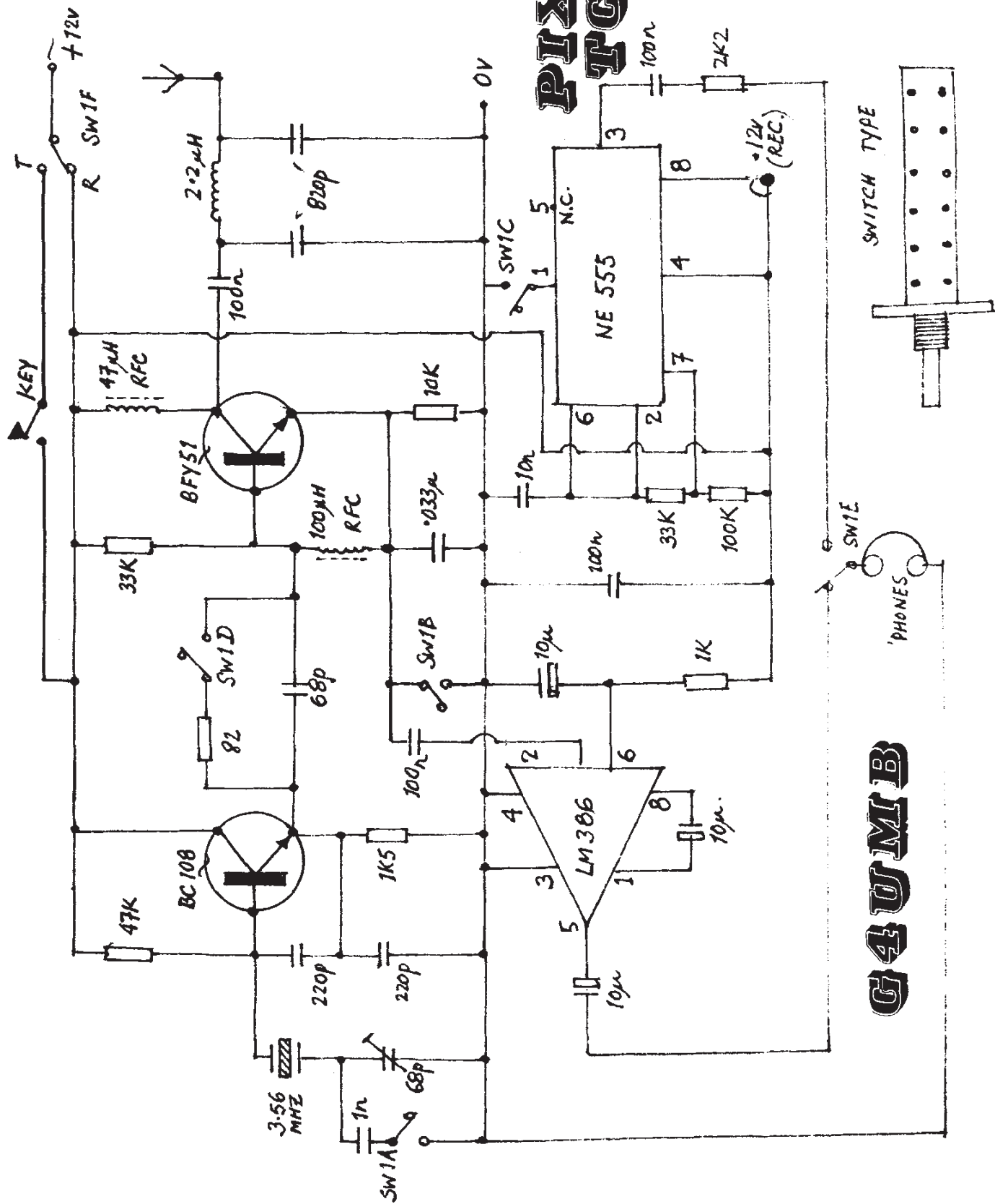

# PIXIE RECEIVER

# G4UMB

SWITCH TYPE

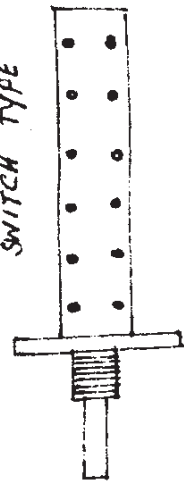

## The FOXX-3

Derek Alexander G4GVM, 52 Brockington Rd. Bodenham, HEREFORD. HR1 3LP

Never having seen this circuit, or its predecessors, I was intrigued by the FOXX - 2 (SPRAT 91) and impressed by the results on 80M - it gave me 1 Watt output and a good number of QSO's.

For me, the essence of this diminutive transceiver is the oscillator and PA/mixer and I see no reason to make life difficult with such low audio, manual changeover and no sidetone.

Leaving the basic circuit as it stands, I set about removing the audio, keying transistor and manual changeover switch, and adding the circuits, which replace them, together with the sidetone oscillator. I venture to call it the FOXX - 3.

The circuits are self-explanatory, but note the addition of the 82p cap on 80M to increase the offset to about 500 Hz and the diode to stop the 12v on RX operating the sidetone.

The new audio circuit, which includes a pre-amp, uses very few components and gives a substantial increase in level, driving an 8 ohm speaker easily. A muting circuit has been included to reduce the thumps on changeover and is worth the additional components. I have used the second input port of the LM386 for the sidetone oscillator, whose positive line is keyed with the PA.

Phase shift oscillators need plenty of gain and a BC109 or better is required here.

### Summary of changes to original circuit:

1. Insert IN4148 between Atx and junction C3/RI
2. Insert 82p cap between Btx and junction CI/Xtal, for 80M only.
3. Replace existing audio with Fig 2.
4. Replace TR3, associated keying components and changeover switch, with Fig 3
5. Add phase shift oscillator, Fig 4.
6. Possibly substitute the 1K pot with a suitable "plug-in" resistor (eg 3K9 for 80M - lower for 40, 20 etc).

I have found low profile DIL socket pins, which plug in to each other, provide a useful source from which to construct plug-in units such as low pass filters.

This fascinating little fun-circuit is great to use. Mine measures 2" x 2.6" x 1.25" high.

Refer also to SPRAT 91.

## N.B.T.V.A.

**The Narrow Bandwidth TV Association** (founded 1975) is dedicated to low definition and mechanical forms of ATV and introduces radio amateurs to TV at an inexpensive level based on home-brew construction. NBTVA should not be confused with SSTV which produces still pictures at a much higher definition. As TV base bandwidth is only about 7kHz, recording of signals on audiocassette is easily achieved. A quarterly 12-page newsletter is produced and an annual exhibition is held in April/May in the East Midlands. If you would like to join, send a crossed cheque/postal order for £4 (or £3 plus a recent SPRAT wrapper) to Dave Gentle, G4RVL, 1 Sunny Hill, Milford, Derbys, DE56 0QR, payable to "NBTVA".



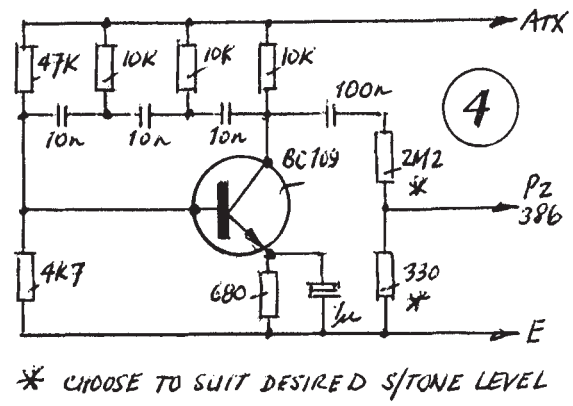
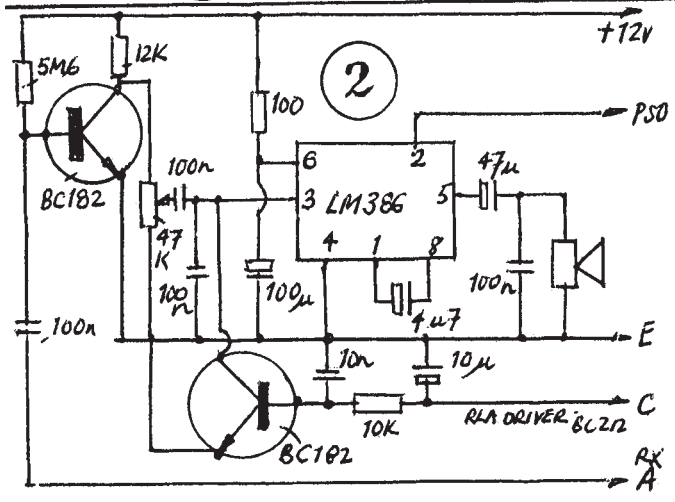
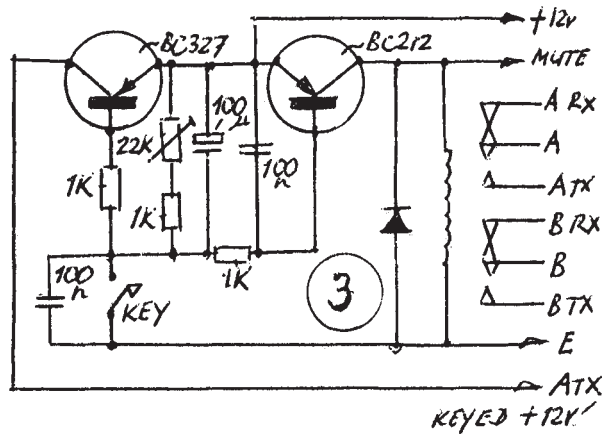
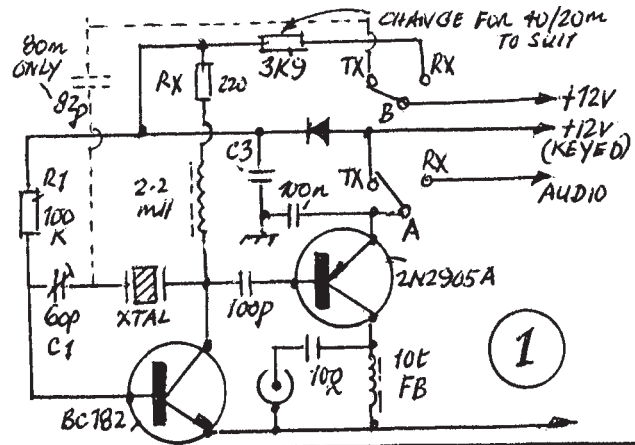

## KANGA PRODUCTS

### New! The FOXX-3 Transceiver



You may have heard of the Pixie, the VU Mini and the Micro 80. All of these transceivers use the PA transistor as the receive mixer, but the original idea came from the UK and the well-known QRPer George Burt GM3OXX in 1982. It first appeared in SPRAT in 1983.

The FOXX-3 is the latest version of the ever-popular FOXX. Designed by Derek Alexander, it incorporates a sidetone oscillator, changeover relay and low-pass

filter. It fits inside an Altoids (TM) mint tin and all connections are made via vertical connectors which are concealed when the lid is closed. The connections are as follows: antenna via 50 ohm BNC, power via 2.1mm co-axial connector or 2 pin 0.1" header, headphones via 3.5mm mono or stereo jack plug or 2 pin header, Morse key via 3.5mm mono or stereo jack plug or 2 pin header. We also supply a small PCB-mounted switch which can be used as the key for ultimate portability. All you need to add are a 12 volt DC supply, headphones and an antenna and tuner. The picture shows the first FOXX-3 built on a production PCB. Note the screen printing which identifies all component positions. The optional push-switch Morse key is fitted.

Richard Newstead, G3CWI, recently operated a 40m FOXX-3 from the summits of Snowdon and Scafell Pike, the two highest peaks in Wales and England, in a single weekend. Despite sub-zero temperatures, Richard made 20 contacts in a total operating time of 80 minutes. Richard told me, "FOXX performed brilliantly. Sidetone stops at -10 degrees C but radio still seemed OK." "I didn't build any additional filtering for the FOXX and it worked really well. No BC breakthrough at all on either day."

The FOXX-3 was launched at the Rochdale QRP Mini-Convention on October 28th 2000.

Visit Kanga Products on their [webpage](#)